

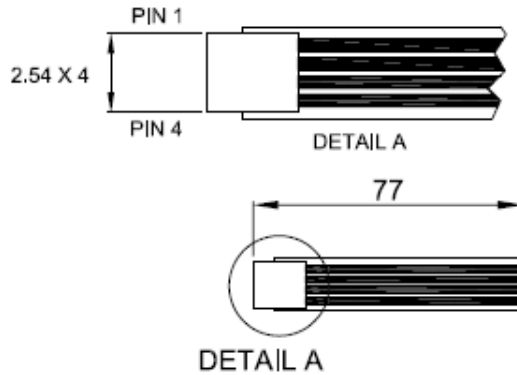

CONNECTOR PINOUT	
PIN NO	ASSIGNMENT
1	Y up
2	X right
3	X left
4	Y down

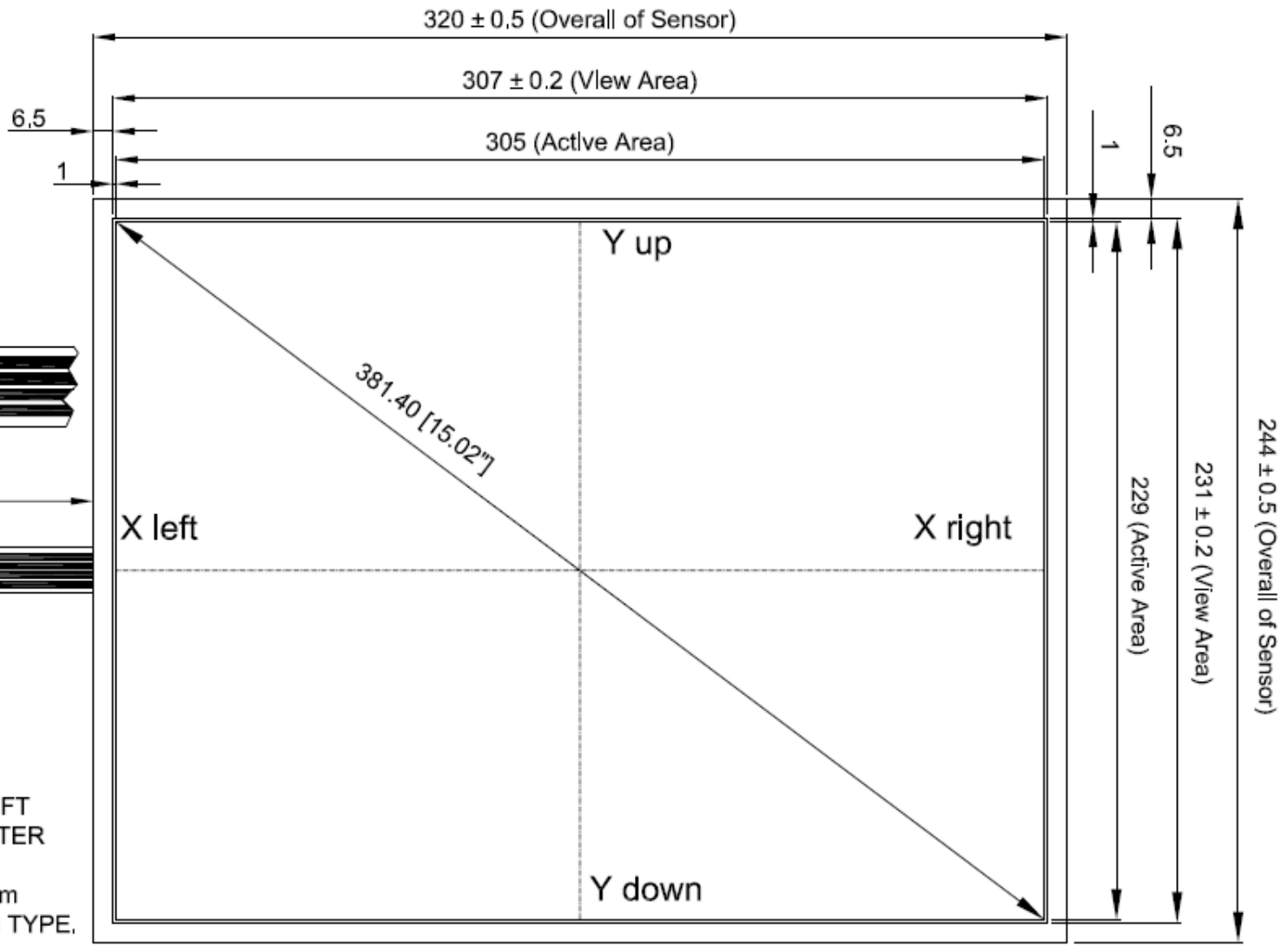

NOTE:
 1. CABLE IS ATTACHED TO THE LEFT SIDE OF TOUCH PANEL AT CENTER POINT AS SHOWN.
 2. TAIL CONNECTOR; PITCH 2.54mm
 3. ITO FILM IS ANTI-NEWTON RING TYPE.



瞄準科技有限公司 AIM TOUCH TECHNOLOGY CO.,LTD.	DATE : 2010/01/06	Part Number	ITO Film Type	Glass Type	Glass Thickness	Finished Part Thickness
	MODEL : AIM-4R-1500-A01	AIM-4R-1500-A01-G1N	ANTI GLARE	General	1.1mm	1.4mm±0.2
 WWW.AIMTOUCH.COM		AIM-4R-1500-A01-G2N	ANTI GLARE	General	1.8mm	2.1mm±0.2
		AIM-4R-1500-A01-G3N	ANTI GLARE	General	2.8mm	3.1mm±0.2

NOTE : All indications are the millimeters.