

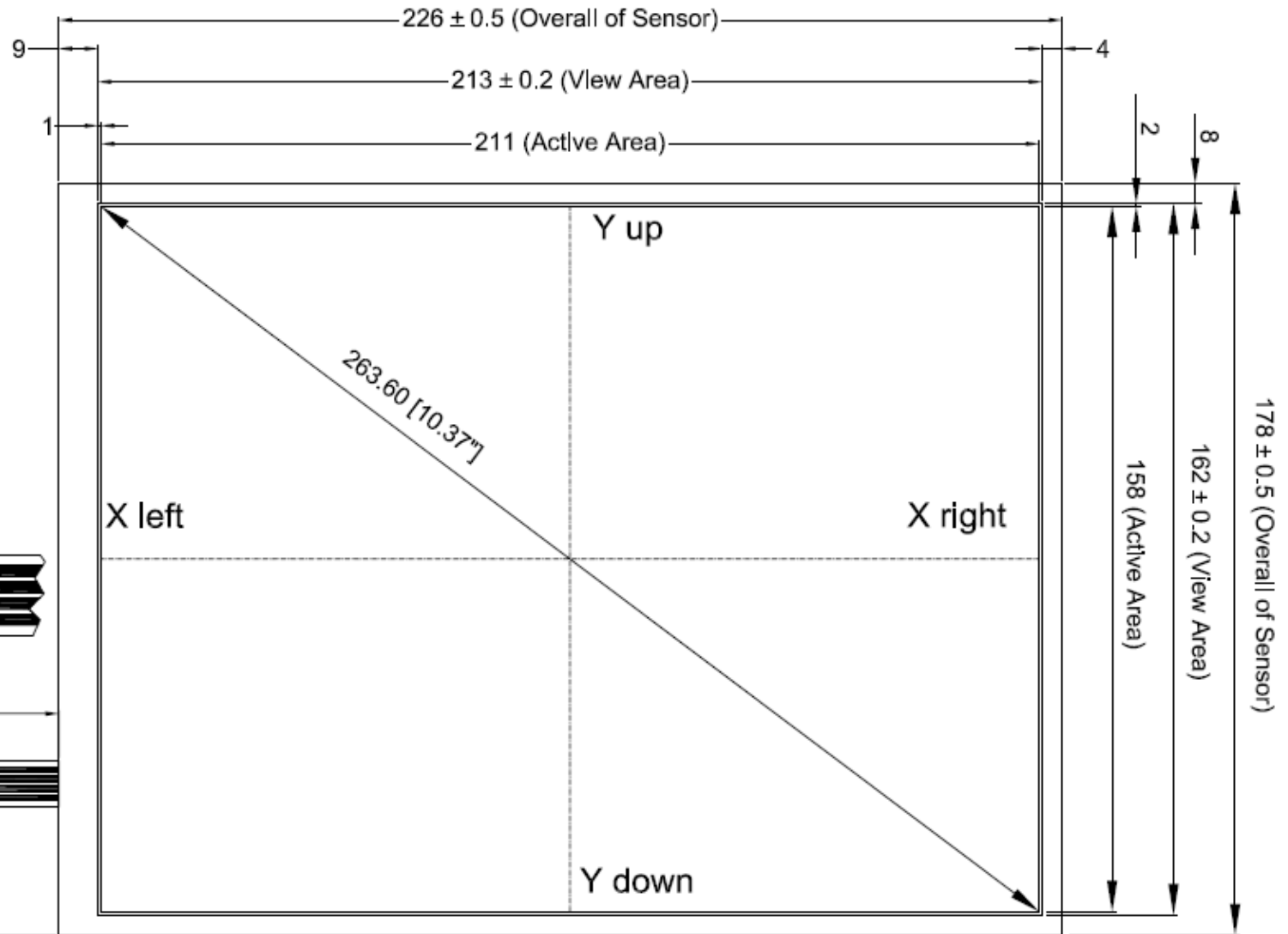

NOTE:  
 1.CABLE IS ATTACHED TO THE LEFT SIDE OF TOUCH PANEL AT CENTER POINT AS SHOWN.  
 2.TAIL CONNECTOR;PITCH 2.54mm

CONNECTOR PINOUT	
PIN NO	ASSIGNMENT
1	Y up
2	X right
3	X left
4	Y down

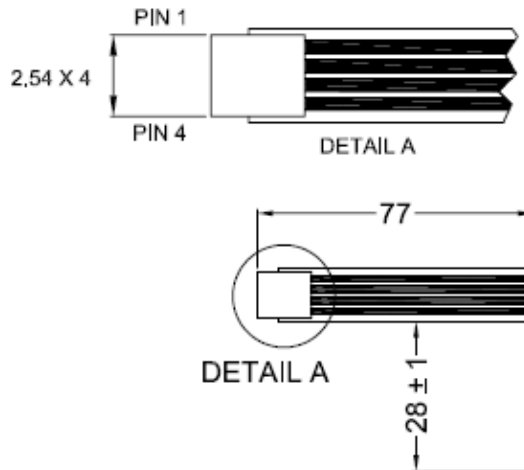

瞄準科技有限公司 AIM TOUCH TECHNOLOGY CO.,LTD.	DATE : 2010/01/04	Part Number	ITO Film Type	Glass Type	Glass Thickness	Finished Part Thickness
	MODEL :	AIM-4R-1040-A02-G0N	ANTI GLARE	General	0.7mm	1.0mm±0.2
 WWW.AIMTOUCH.COM	AIM-4R-1040-A02	AIM-4R-1040-A02-G1N	ANTI GLARE	General	1.1mm	1.4mm±0.2
		AIM-4R-1040-A02-G2N	ANTI GLARE	General	1.8mm	2.1mm±0.2

NOTE : All indications are the millimeters.